



# Bray®

**SERIES 90/91**  
 Double Acting / Spring Return  
 316 Stainless Steel

## **PNEUMATIC ACTUATOR**

RACK & PINION / OUTPUT TORQUE: FROM 50 TO 8675 LB.-INS.

Bray Controls takes pride in introducing the Stainless Steel Series 90/91 quarter turn pneumatic actuator. These rack and pinion, opposed-piston actuators have been designed to incorporate innovative, high performance features into a compact, rugged and reliable modular product line. All models are suitable for both on/off and throttling applications. The 316 Stainless Steel construction provides excellent internal and external corrosion resistance, making these actuators ideal for chemical, sanitary, food and beverage, marine, mining and pharmaceutical applications.

**FEATURES** Available in two versions: double acting and spring return, Series 90/91 actuators deliver high output torque in an efficient, space-saving housing. With a low coefficient of friction, the Series 90/91 provides superior high-cycle, long lasting service. All piston guides, piston rings and output shaft bearings are permanently lubricated, manufactured from acetal material, offering a very low coefficient of

friction between the piston cylinder walls and actuator body. No field lubrication of the Series 90/91 is needed under normal operating conditions.

**POSITION INDICATOR** provides clearly visible indication of valve position through the full range of travel.

**MANUAL OVERRIDE** Double D shaft is readily accessible for actuator override when required.

**ACTUATOR MOUNTING** Actuators comply with ISO 5211 standards for mounting of actuators to valves. A double D shaft is standard. A double square shaft is available. The Series 90/91 has been designed to mount directly to Bray valves without the need of brackets or adapters.

**ACCESSORY MOUNTING** Actuators meet NAMUR standards (VDI/VDE 3845) for accessory mounting.

# SERIES 90/91 SS

**SPRING RETURN** Bray's Series 91 spring return models employ a unique cartridge system. The spring cartridges offer our customers safety, simplicity and reduced space requirements. The actuator can be easily disassembled and assembled without cumbersome equipment or any danger to the installer. Converting from double acting to spring return actuation is simply a matter of removing the end caps and adding the unique spring cartridges. The housing length of the spring return model is the same as the double acting model, except size 48 actuators.

**TRAVEL STOP** Adjusting screws are located in both end caps to precisely limit travel of the actuator to specific degrees of rotation. The travel stop permits field readjusting of actuator movement to open or closed positions. For open and closed bi-directional adjustment, a travel stop positioned on center of the output shaft is available as an option.

## STANDARD MATERIALS

- Body: 316 Stainless Steel (ASTM A351 CF8M)
- End Caps: 316 Stainless Steel (ASTM A351 CF8M)
- Pistons: • Die Cast Aluminum Alloy  
• 316 Stainless Steel (ASTM A351 CF8M) available as an option
- Output Shaft: 316 Stainless Steel (ASTM A276)
- Shaft Bearings: Acetal
- Piston Guides: Acetal
- Fasteners: 18-8 Stainless Steel
- Springs: Spring Steel, protective coating
- O-ring Seals: Buna-N

## SUPPLY PRESSURE

Maximum: 140 psi (10 Bar) Air. Other media such as hydraulic oil or water are available as an option.

## TEMPERATURE RATINGS

-40°F (-40°C) to 200°F (95°C)

**TORQUE DATA** Please refer to Bray Brochure B-1003.

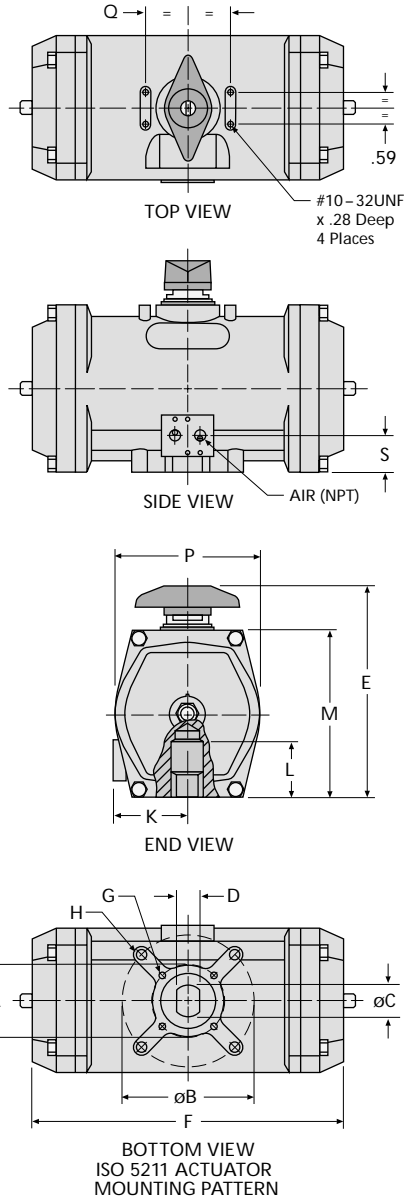

## ACTUATOR SPEEDS

SIZE	48	63	92	127	160
Open Stroke/ Close Stroke	1/4	1/4	1/4	1/2	1

Times are in seconds, at 80 PSIG with 6ft. tubing, internal diameter approximately 1/4".

## ACTUATOR DIMENSIONS

SIZE	48	63	92	127	160
AIR NPT	1/8	1/4	1/4	1/4	1/4
A ISO "F"†	1.42 F 03	1.97 F 05	1.97 F 05	2.76 F 07	—
B ISO "F"†	1.97 F 05	2.76 F 07	2.76 F 07	4.92 F 12	4.92 F 12
C	.55	.55	.75	1.18	1.18
C1	.71	.71	.87	1.42	1.42
D	.40	.40	.51	.87	.87
D1	.55	.55	.67	1.06	1.06
E	3.94	4.61	5.77	7.33	9.20
F	3.94*	5.46	8.15	9.94	14.76
G (UNC)	#10-32 x .21	1/4-20 x 5/16	1/4-20 x 5/16	5/16-18 x 3/8	—
H (UNC)	1/4-20 x 1/4	5/16-18 x 3/8	5/16-18 x 3/8	1/2-13 x 11/16	1/2-13 x 3/4
J	.38	.38	.50	1.12	1.12
K	1.88	1.86	2.25	2.82	3.27
L	1.30	1.38	1.46	2.20	2.20
M	2.81	3.46	4.61	6.32	7.79
P	3.06	3.24	4.22	5.52	6.77
Q	1.58	1.58	1.58	1.58	2.56
S	1.25	.89	.99	1.41	1.61
T	.787	.787	.787	.787	1.181
U	.47	.47	.47	.47	.75

**Note:** \*Double Acting (Series 90) and Spring Return (Series 91) actuators have the same overall dimensions, except Size 48 actuators, F Dimensions (Length) = 6.10.

† ISO "F" means mounting flange-drilling pattern.

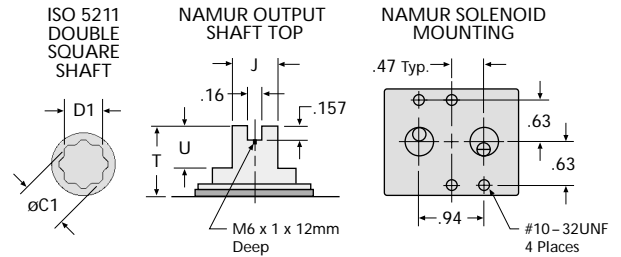

DISTRIBUTOR

All statements, technical information, and recommendations in this bulletin are for general use only. Consult Bray representatives or factory for the specific requirements and material selection for your intended application. The right to change or modify product design or product without prior notice is reserved.

Patented and patents applied for all over the world. Bray® is a registered trademark of BRAY INTERNATIONAL, Inc.



A Division of BRAY INTERNATIONAL, Inc.  
13333 Westland East Blvd. Houston, Texas 77041  
281.894.5454 FAX 281.894.9499 www.bray.com

© 2001 Bray International. All rights reserved.

B-1027 10/01